

## Description

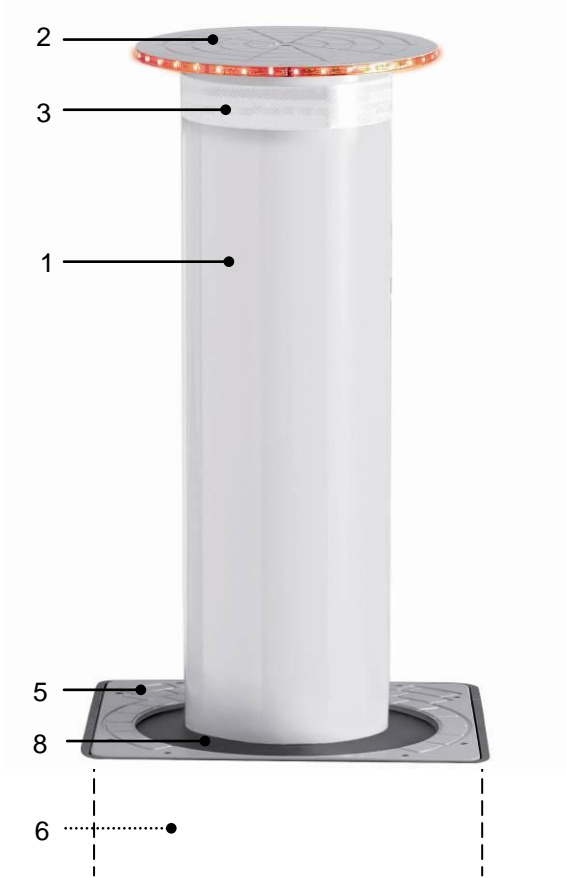

RB90 K4 illustrated with optional color for the obstacle

1. Security obstacle comprising a 275 mm diameter, 10 mm thick steel cylinder.
2. 30 mm thick cast aluminium crown.
3. 55 mm reflective strip.
4. Mobile obstacle supported on a thick steel section supporting structure.
5. 5 mm thick cast aluminium cover plate.
6. Galvanized sheet steel embedded casing with a normal steel at the top for attaching the obstacle.
7. Mobile obstacle is held vertically and strengthened by means of a thick steel collar connected to the supporting structure and a nylon bush built-in to the obstacle and sliding along the central jack.
8. Synthetic joint.
9. Plunger central hydraulic jack for raising and lowering the obstacle.  
Obstacle not fixed to the jack to limit damages caused by small shocks.
10. Hydraulic unit mounted on the supporting structure producing 40 bars to maintain the obstacle in the raised position.
11. Obstacle stopped in raised and lowered positions by mechanical stops.
12. Steel/rubber bearings support the obstacle when in the retracted position, allowing it to withstand the passage of heavy vehicles (40T – Class Load D400).
13. Inductive sensors for raised and lowered position status information.
14. Remote microprocessor control board, separated from the obstacle (10 m of electric cable provided), dipswitch programming, LED display for obstacle status and inputs/outputs used.

The RB90 **S**ecurity automatic rising bollard is designed to protect and control access to sites that are susceptible to attempted break-in. It can be used on any site where it is wished to create an obstacle to traffic without restricting pedestrian access. In urban environments, it has the advantage of being completely invisible when lowered. It is also perfect for controlling vehicle access to pedestrian areas.

The security bollards have greater impact resistance than that of the other obstacles in the range (see technical characteristics below).

**Surface protection**

- Bollard: anticorrosion galvanizing treatment + polyester powder paint.  
Mobile obstacle: grey anthracite RAL 7016.  
Crown + cover plate: light grey RAL 9006.
- Casing: galvanization in aluzinc.
- Jack: surface anodizing.

**Standard technical characteristics**

Impact resistance:	<ul style="list-style-type: none"> <li>• 60,000 joules, with guaranteed operation;</li> <li>• 700 000 joules, with permanent deformation. (= theoretical K4: stops a 6.8 ton [15000 lb] vehicle launched at 48 km/h [30 mi/h])</li> </ul>
Electrical power supply:	230 V single phase. (do not connect to a floating network or to high impedance earthed industrial distribution network)
Frequency:	50/60 Hz.
Nominal power:	900 W.
Raising speed:	10 cm/s
Lowering speed:	20 cm/s.
Operating temperature:	- 15 to + 60°C.
Frequency of use:	2,000 operations per day.
Mean Cycles Between Failure:	2,000,000 cycles, respecting the recommended maintenance
Weight:	384 kg (bollard: 210 kg; pit: 174 kg).
Protection index	IP 67 for hydraulic components
CE	Complies with European standards

**Options**

1. Indicator lights (LEDs in the perimeter of the crown) – flashing with or without warning given prior to obstacle operation.
2. Intermittent audible signal with or without warning given prior to obstacle operation.
3. Heating resistance for operation at a temperature down to -40° C in case of use in areas that are highly exposed to snow or prolonged freezing.
4. Hermetically sealed, embedded casing fitted with an immersion pump if direct drainage or connection to mains drainage is not possible.
5. Additional cable lengths (to connect the bollard unit to the central logic box) (maximum length: 80 meters).
6. Push button box.
7. Radio transmitter/receiver.
8. Vehicle inductive loop.
9. Presence detector for inductive loop.
10. Emergency Fast Opening (EFO: 1 s).
11. Mobile obstacle in AISI 304 brushed stainless steel.
12. Paint of another RAL color for the mobile obstacle.
13. Alarm in case of lowering attempts of the obstacle.
14. Control board for 2 to 8 synchronous bollards.
15. Dry contacts for bollard position information (up/down).
16. Anti tampering screws for the cover plate (access to manual unlocking).
17. Antirust crown for the perimeter of the cover plate.
18. Automatic lowering in case of power failure.
19. UPS (backup power in case of power failure).

**Standard dimensions (mm)**

**Work to be realised by the customer**

- Embedding casing in a concrete foundation (refer to installation drawing).
- Drainage or connection to mains drainage (if necessary).
- Power supply.
- Electric connections with external peripherals.

